

General Description

The SQ24301 is a super low dropout LDO regulator with small package, capable of delivering up to 1A output current.

Ordering Information

SQ24301 □(□□□)
 └─── Package Code
 └─── Optional Spec Code

Ordering Number	Package type	Note
SQ24301DSD	DFN3×3-6	----

Features

- Input Voltage Range: 1.6-5.5V
- Output Voltage Accuracy: $\pm 5\%$
- Up to 1A Output Current
- Low Dropout Voltage:
 - Typ. 0.32V at $I_{OUT}=1A, V_{OUT}=1.5V$
 - Typ. 0.18V at $I_{OUT}=1A, V_{OUT}=2.8V$
- Current Limiting Protection
- Thermal Shutdown Protection
- Quiescent Current: 60 μA
- Output Auto-discharge Function
- Over Temperature Protection
- RoHS Compliant and Halogen Free
- Compact Package: DFN3×3-6

Applications

- Portable Communication Equipments
- Hand-Held Instruments, Notebook PC
- Camcorders and Cameras

Typical Applications

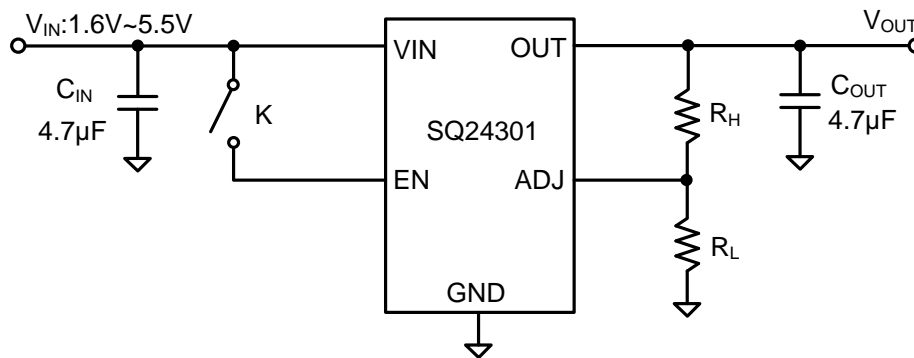
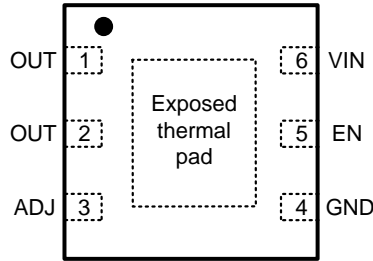

Figure1. Schematic Diagram

Pinout (top view)



(DFN3×3-6)

Top mark: 8Txyz for SQ24301DSD (Device code: 8T, *x*=year code, *y*=week code, *z*=lot number code)

Pin Name	Pin Number	Pin Description
OUT	1, 2	Output pin. Decouple this pin to the GND pin with at least a 4.7μF ceramic capacitor.
ADJ	3	Output voltage programming pin. Connect this pin to the center point of the output resistor divider (as shown in Figure 1) to program the output voltage: $V_{OUT}=1.0V \times (1+R_H/R_L)$.
GND	4	Ground pin.
EN	5	Enable control pin. A 5MΩ pull-down resistor is integrated.
VIN	6	Input pin. Decouple this pin to the GND pin with at least a 4.7μF ceramic capacitor.

Block Diagram

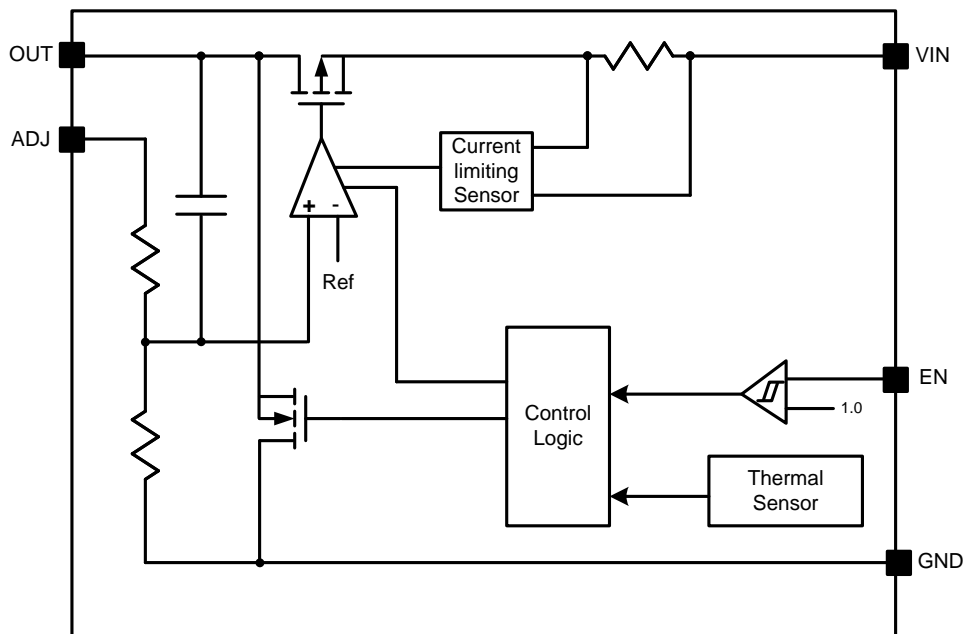

Figure2. Block Diagram



Absolute Maximum Ratings (Note 1)

IN, EN	-----	6.0V
Power Dissipation, PD @ TA = 25°C DFN3×3-6	-----	2W
Package Thermal Resistance (Note 2)		
θJA	-----	50°C/W
θJC	-----	15°C/W
Junction Temperature Range	-----	150°C
Lead Temperature (Soldering, 10 sec.)	-----	260°C
Storage Temperature Range	-----	-65°C to 150°C

Recommended Operating Conditions (Note 3)

Supply Input Voltage	-----	1.6V to 5.5V
Junction Temperature Range	-----	-40°C to 125°C
Ambient Temperature Range	-----	-40°C to 85°C

Electrical Characteristics

(VIN = 5V, CIN=4.7μF, COUT=4.7μF. TJ = -40°C to +125°C. Typical values are at TJ = 25°C, unless otherwise specified. The values are guaranteed by test, design or statistical correlation.)

Parameter	Symbol	Test Conditions	Min	Typ.	Max	Unit
Input Voltage Range	VIN		1.6		5.5	V
Supply Current	ISS	VEN=VIN=2V, VOUT=VADJ, IOUT=0A		60	100	μA
Shutdown Current	ISD	VIN=6.0V, VEN=0		0.1	10	μA
Output Voltage Accuracy	ΔVOUT	VOUT=VADJ, VIN=2.0V, IOUT=100mA	0.95		1.05	V
Output Voltage Range	VOUT		1.0		VIN	V
Current Limit	ILIM		1.0			A
Load Regulation	ΔVOUT/ΔIOUT	VOUT=VADJ, VIN=2.0V 1mA ≤ IOUT ≤ 1A		-3		mV/A
Line Regulation	ΔVOUT/ΔVIN	VOUT=VADJ, IOUT=100mA 2.0 ≤ VIN ≤ 5.5V		0.05	0.3	%/V
EN Pull-down Resistance	REN			5		MΩ
Ripple Rejection	RR	f=1kHz, Ripple 0.5VPP VOUT=VADJ, VIN=2.5V, IOUT=100mA		-60		dB
Output Voltage Temperature Coefficient	ΔVOUT/ΔT	IOUT=100mA -40°C ≤ TJ ≤ 85°C		±100		ppm/°C
Short Current Limit	ISHORT	VOUT=0V		250		mA
Discharge Resistor	RDISCHG			100		Ω
EN Rising Threshold	VENH		1.0			V
EN Falling Threshold	VENL				0.3	V
Thermal Shutdown Temperature (Note 4)	TSD			150		°C
Thermal Shutdown Hysteresis (Note 4)	THYS			20		°C
Dropout Voltage	VDROP	Refer to the following table				



Dropout Voltage by output Voltage

$T_J = -40^{\circ}\text{C}$ to $+125^{\circ}\text{C}$.

Output Voltage(V) V_{OUT}	Dropout Voltage V_{DROP} (V)		
	$I=300\text{mA}$		$I=1\text{A}$
	Typ.	Max	Typ
$1.0\text{V} \leq V_{OUT} < 1.5\text{V}$	0.18	0.32	0.50
$1.5\text{V} \leq V_{OUT} < 2.6\text{V}$ (Note 4)	0.10	0.15	0.28
$2.6\text{V} \leq V_{OUT}$ (Note 4)	0.05	0.10	0.18

Note 1: Stresses beyond the “Absolute Maximum Ratings” may cause permanent damage to the device. These are stress ratings only. Functional operation of the device at these or any other conditions beyond those indicated in the operational sections of the specification is not implied. Exposure to absolute maximum rating conditions for extended periods may affect device reliability.

Note 2: θ_{JA} is measured in the natural convection at $T_A = 25^{\circ}\text{C}$ on a two-layer Silergy evaluation board.

Note 3: The device is not guaranteed to function outside its operating conditions.

Note 4: Guaranteed by design.

Typical Operating Characteristics

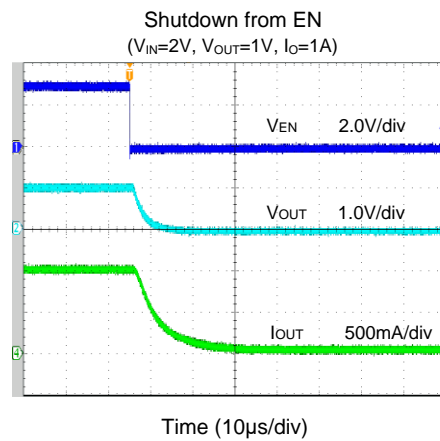
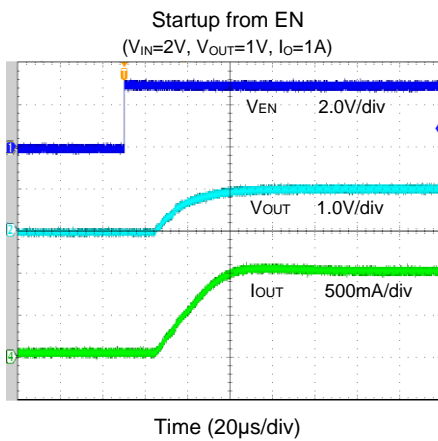
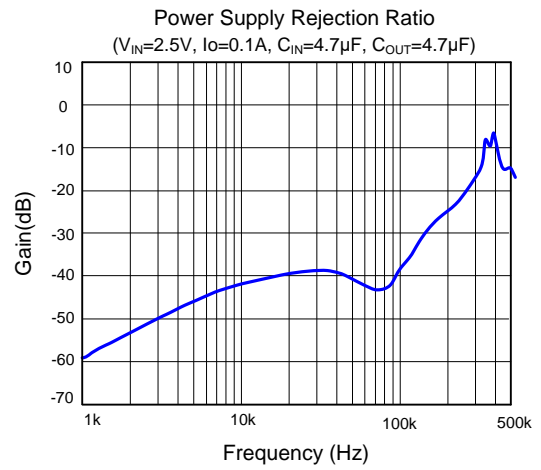
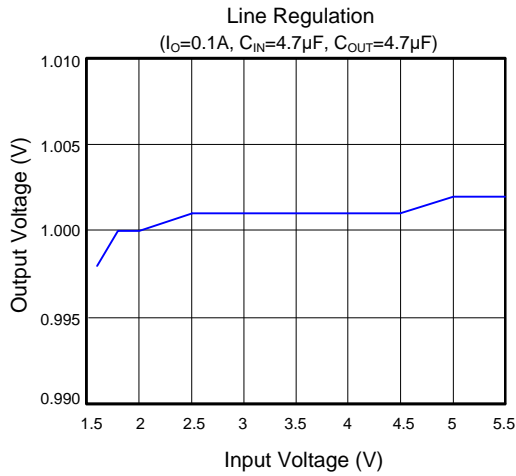
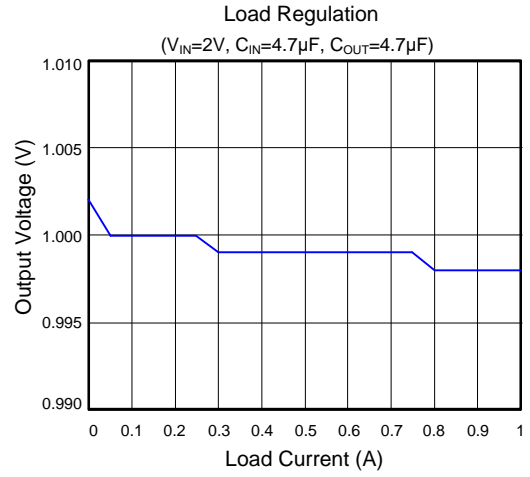
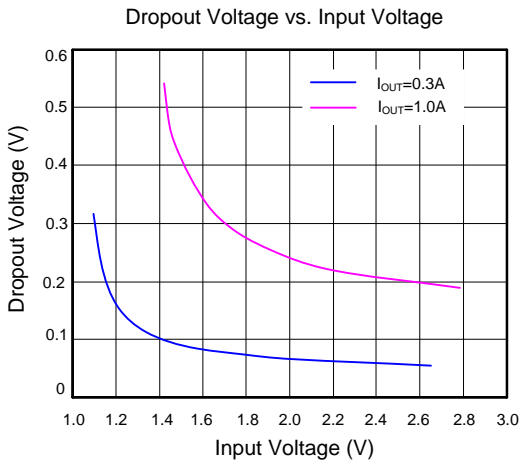

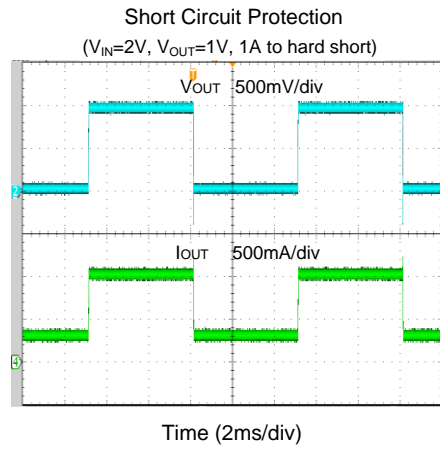
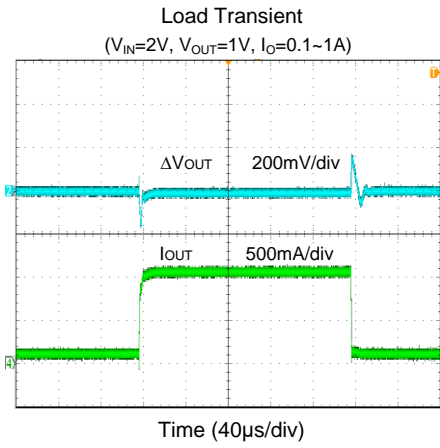

Operation Information

The SQ24301 is a super low dropout LDO regulator with small package, capable of delivering up to 1A output current.

Input Capacitor C_{IN}:

An input capacitor about 4.7μF is required between the device input pin and ground pin. A typical X5R or better grade ceramic capacitor with 6V rating is recommended in this application. This input capacitor must be located close to the device to assure the input stability. A lower ESR capacitor allows the use of less capacitance, while higher ESR type requires more capacitance.

Output Capacitor C_{OUT}:

For transient stability, the SQ24301 is designed specifically to work with very small ceramic output capacitors. A 4.7μF output capacitor with 10mΩ to 50mΩ ESR range (like X7R or X5R) can be used in this application. Higher capacitance values help to improve transient. The output capacitor's ESR is critical because it forms a zero to provide phase lead which is required for loop stability.

Output Voltage Setting:

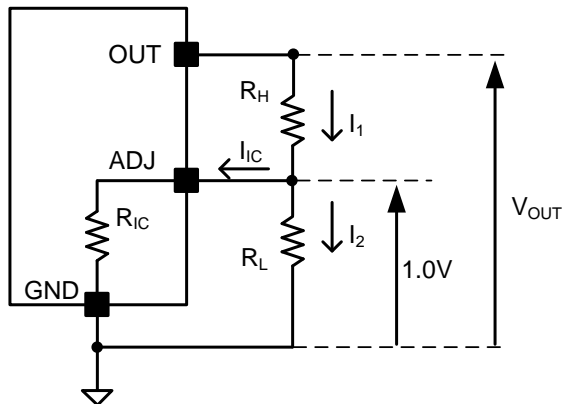

The Output Voltage may be adjustable for any output voltage between its 1.0V reference and its V_{IN} setting level. An external pair of resistors is required, as shown above.

The complete equation for the output voltage is described as follows:

$$V_{OUT} = 1.0 + R_H (I_{IC} + 1.0/R_L);$$

$$\text{Thus, } V_{OUT} = 1.0(1 + R_H/R_L) + R_H \times I_{IC};$$

Therefore, $R_H \times I_{IC}$ will produce an error in V_{OUT} .

For better accuracy, choosing $R_L \ll R_{IC}$ (1.45MΩ) reduces this error.

$$\text{So, } V_{OUT} = 1.0(1 + R_H/R_L), (R_L \ll R_{IC}).$$

No Load Stability:

The device will remain stable and in regulation with no external load. This is especially important in CMOS RAM keep-alive applications.

Dropout Voltage:

The SQ24301 has a very low dropout voltage due to its extra low $R_{DS(ON)}$ of the main PMOS determines the lowest usable supply voltage. In battery-powered systems, the dropout voltage is a regulator's minimum $V_{IN} - V_{OUT}$, which determines the useful end-of-life battery voltage:

$$V_{DROPOUT} = V_{IN} - V_{OUT} = R_{DS(ON)} \times I_{OUT}$$

Current Limit:

The minimum current limit of the SQ24301 is 1A.

Short-circuit Protection

The device is short circuit protected and in the event of a peak over-current condition, the short-circuit control loop will rapidly drive the output PMOS pass element off. The thermal shutdown and soft-start circuit will work cycle output on and off until the average power dissipation causes the thermal shutdown circuit to respond to servo the on/off cycling to a lower frequency.

Thermal Considerations:

The SQ24301 can deliver a current of up to 1A over the full operating junction temperature range. However, the maximum output current must be derated at higher ambient temperature to ensure the junction temperature does not exceed 125°C. With all possible conditions, the junction temperature must be within the range specified under operating conditions. Power dissipation can be calculated based on the output current and the voltage drop across regulator.

$$P_D = (V_{IN} - V_{OUT}) \times I_{OUT} + V_{IN} \times I_{GND}$$

The final operating junction temperature for any set of conditions can be estimated by the following thermal equation:

$$P_{D(MAX)} = (T_{J(MAX)} - T_A) / \theta_{JA}$$

Where $T_{J(MAX)}$ is the maximum junction temperature of the die and T_A is the maximum ambient temperature.

Layout Design:

Good board layout practices must be used or instability can be induced because of ground loops and voltage drops, and large PCB copper area can improve the thermal performance. The input and output capacitors MUST be directly connected to the input, the output, and the ground pins of the device using traces which have no other currents flowing through them. The feed back loop formed by R_L , R_H and the trace connecting to the ADJ pin and the OUT must be minimizing.

The best way to do this is to layout C_{IN} and C_{OUT} near the device with short traces to the V_{IN} , V_{OUT} , and ground pins. The regulator ground pin should be connected to the external circuit ground so that the regulator and its capacitors have a “single point ground”.

Below is the recommended PCB Layout diagram:

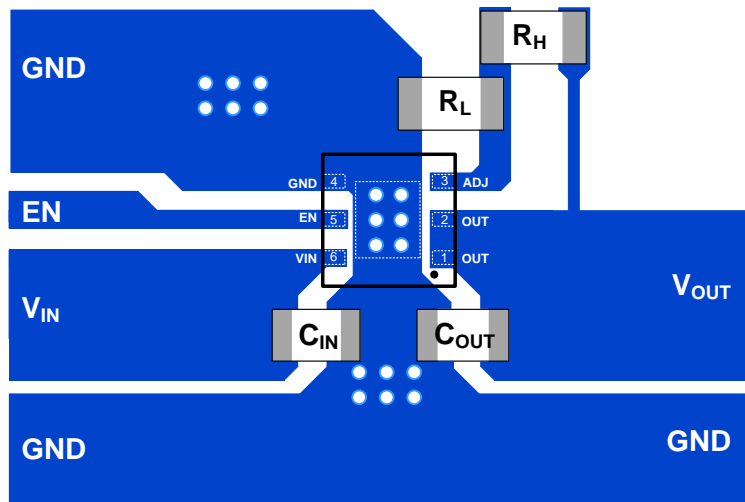
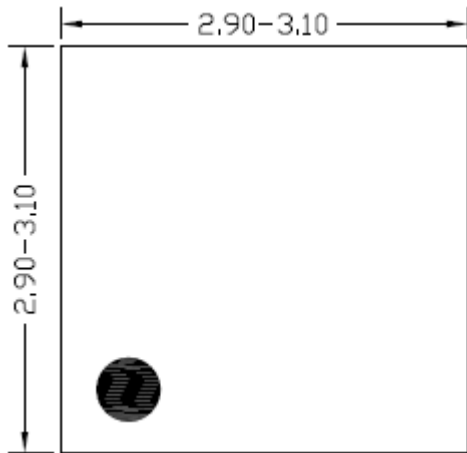
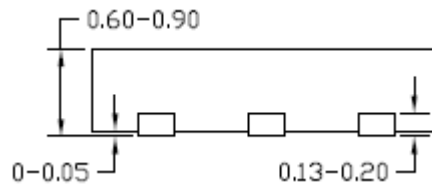

Figure3. PCB Layout Suggestion

DFN3×3-6 Package Outline Drawing



Top View



Side View

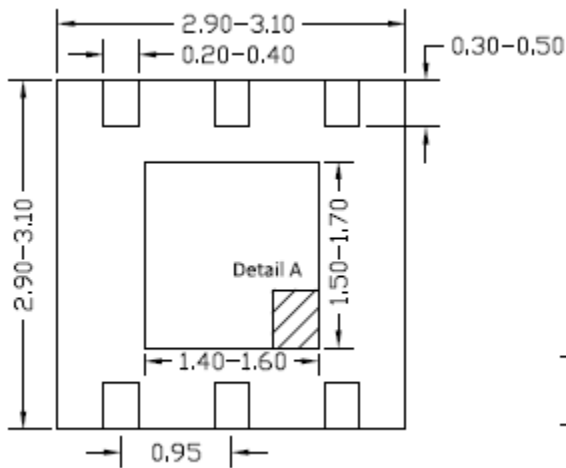

Bottom View



Detail A
Pin1 Identifier: two options

Notes: All dimension in millimeter and exclude mold flash & metal burr

Taping & Reel Specification

1. DFN3×3 taping orientation

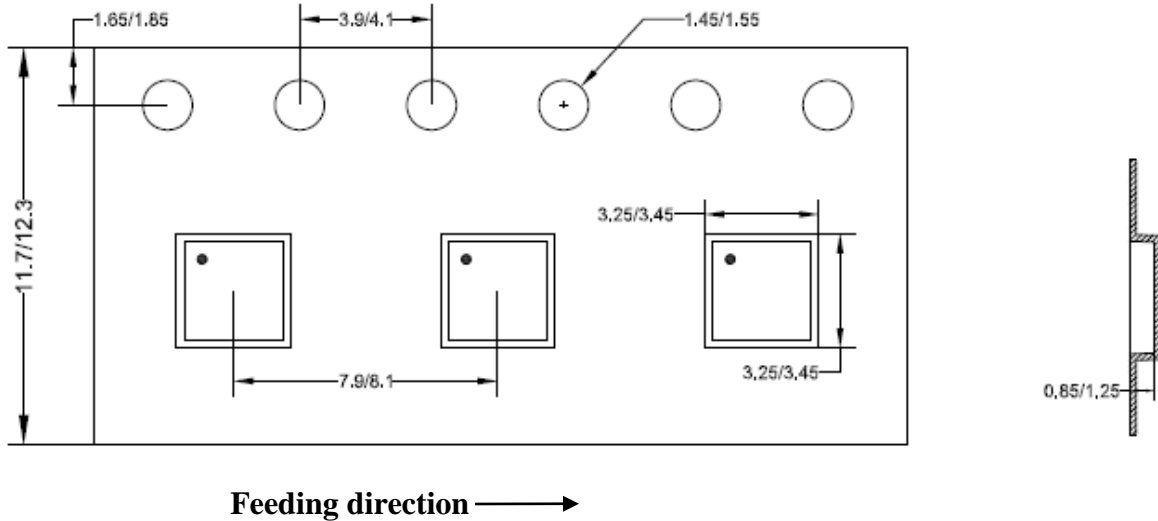

2. Carrier Tape & Reel specification for packages

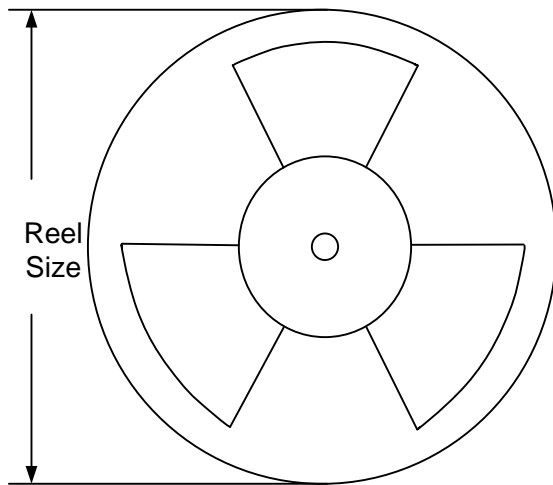

Package type	Tape width (mm)	Pocket pitch(mm)	Reel size (Inch)	Trailer length(mm)	Leader length (mm)	Qty per reel
DFN3×3	12	8	13"	400	400	5000

3. Others: NA



Revision History

The revision history provided is for informational purpose only and is believed to be accurate, however, not warranted. Please make sure that you have the latest revision.

Date	Revision	Change
Mar.17, 2021	Revision 0.9	Initial Release



IMPORTANT NOTICE

- 1. Right to make changes.** Silergy and its subsidiaries (hereafter Silergy) reserve the right to change any information published in this document, including but not limited to circuitry, specification and/or product design, manufacturing or descriptions, at any time and without notice. This document supersedes and replaces all information supplied prior to the publication hereof. Buyers should obtain the latest relevant information before placing orders and should verify that such information is current and complete. All semiconductor products are sold subject to Silergy's standard terms and conditions of sale.
- 2. Applications.** Application examples that are described herein for any of these products are for illustrative purposes only. Silergy makes no representation or warranty that such applications will be suitable for the specified use without further testing or modification. Buyers are responsible for the design and operation of their applications and products using Silergy products. Silergy or its subsidiaries assume no liability for any application assistance or designs of customer products. It is customer's sole responsibility to determine whether the Silergy product is suitable and fit for the customer's applications and products planned. To minimize the risks associated with customer's products and applications, customer should provide adequate design and operating safeguards. Customer represents and agrees that it has all the necessary expertise to create and implement safeguards which anticipate dangerous consequences of failures, monitor failures and their consequences, lessen the likelihood of failures that might cause harm and take appropriate remedial actions. Silergy assumes no liability related to any default, damage, costs or problem in the customer's applications or products, or the application or use by customer's third-party buyers. Customer will fully indemnify Silergy, its subsidiaries, and their representatives against any damages arising out of the use of any Silergy components in safety-critical applications. It is also buyers' sole responsibility to warrant and guarantee that any intellectual property rights of a third party are not infringed upon when integrating Silergy products into any application. Silergy assumes no responsibility for any said applications or for any use of any circuitry other than circuitry entirely embodied in a Silergy product.
- 3. Limited warranty and liability.** Information furnished by Silergy in this document is believed to be accurate and reliable. However, Silergy makes no representation or warranty, expressed or implied, as to the accuracy or completeness of such information and shall have no liability for the consequences of use of such information. In no event shall Silergy be liable for any indirect, incidental, punitive, special or consequential damages, including but not limited to lost profits, lost savings, business interruption, costs related to the removal or replacement of any products or rework charges, whether or not such damages are based on tort or negligence, warranty, breach of contract or any other legal theory. Notwithstanding any damages that customer might incur for any reason whatsoever, Silergy' aggregate and cumulative liability towards customer for the products described herein shall be limited in accordance with the Standard Terms and Conditions of Sale of Silergy.
- 4. Suitability for use.** Customer acknowledges and agrees that it is solely responsible for compliance with all legal, regulatory and safety-related requirements concerning its products, and any use of Silergy components in its applications, notwithstanding any applications-related information or support that may be provided by Silergy. Silergy products are not designed, authorized or warranted to be suitable for use in life support, life-critical or safety-critical systems or equipment, nor in applications where failure or malfunction of an Silergy product can reasonably be expected to result in personal injury, death or severe property or environmental damage. Silergy assumes no liability for inclusion and/or use of Silergy products in such equipment or applications and therefore such inclusion and/or use is at the customer's own risk.
- 5. Terms and conditions of commercial sale.** Silergy products are sold subject to the standard terms and conditions of commercial sale, as published at <http://www.silergy.com/stdterms>, unless otherwise agreed in a valid written individual agreement specifically agreed to in writing by an authorized officer of Silergy. In case an individual agreement is concluded only the terms and conditions of the respective agreement shall apply. Silergy hereby expressly objects to and denies the application of any customer's general terms and conditions with regard to the purchase of Silergy products by the customer.
- 6. No offer to sell or license.** Nothing in this document may be interpreted or construed as an offer to sell products that is open for acceptance or the grant, conveyance or implication of any license under any copyrights, patents or other industrial or intellectual property rights. Silergy makes no representation or warranty that any license, either express or implied, is granted under any patent right, copyright, mask work right, or other intellectual property right. Information published by Silergy regarding third-party products or services does not constitute a license to use such products or services or a warranty or endorsement thereof. Use of such information may require a license from a third party under the patents or other intellectual property of the third party, or a license from Silergy under the patents or other intellectual property of Silergy.

For more information, please visit: www.silergy.com

©2021 Silergy Corp.

All Rights Reserved.