

High Efficiency, 28V Input Single Inductor Synchronous Step Up/Down Regulator

General Description:

The SY9329B is a high voltage Buck-Boost converter for USB power delivery applications. With user-selectable source mode and sink mode, it features bidirectional power delivery. In source mode, the output voltage V_{VBUS} is 5V, 9V, 10V, 12V, 15V, 20V selectable. In sink mode, the output voltage V_{BAT} is adjustable with an external resistor divider.

The device operates over a wide input voltage range from 4V to 28V and the maximum average inductor current is limited to a typical value of 10A. The four integrated low $R_{DS(ON)}$ switches minimize the conduction loss.

The SY9329B integrates an I²C compatible interface for mode selecting, output voltage setting, frequency setting, protection setting, and etc.

The device is available in compact QFN4×4-32 package.

Ordering Information

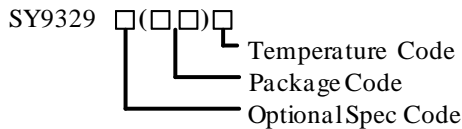

Ordering Number	Package type	Note
SY9329BQFC	QFN4×4-32	

Features:

- Bidirectional Power Delivery: Source Mode and Sink Mode
- 4V to 28V Input Voltage Range
- Low $R_{DS(ON)}$ for Internal Switches: 25mΩ
- Internal Soft-start
- 8-bit ADC for Output Voltage, Input Voltage and VBUS Output Current Detection
- Fully Protected for Output Over Current, Short-circuit and Over-temperature
- I²C Compatible Interface
 - Support Interrupt for Status Feedback
 - Selectable Switching Frequency: 250kHz, 500kHz, 750kHz, 1MHz
 - Selectable VBUS Output Voltage: 5V, 9V, 10V, 12V, 15V, 20V
 - Selectable Inductor Current Limit and VBUS Output Current Limit
- Compact Package: QFN4×4-32
- UL Certificate Number: E491480
- UL 2367 Certified
- IEC/ EN 62368-1 Certified

Applications:

- Docking Station
- Laptop
- High-end Power Bank
- Monitor
- Car Charger
- USB PD

Typical Application

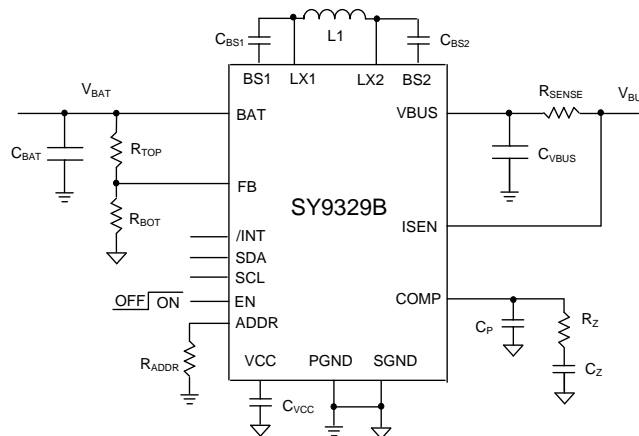
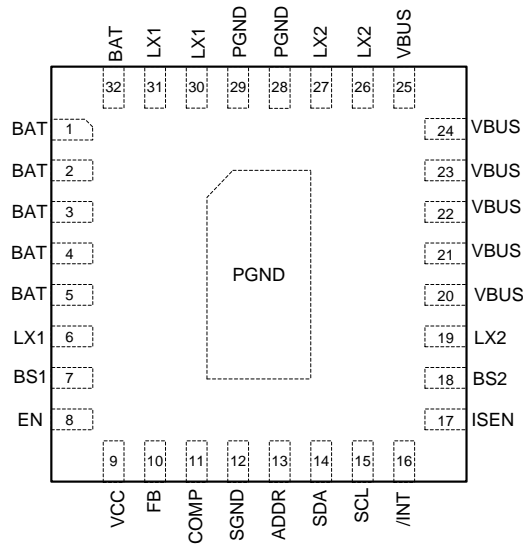

Figure1. Typical Schematic Diagram

Pinout (Top View)

(QFN4×4-32)

Top Mark: BSZxyz (Device code: BSZ, *x*=year code, *y*=week code, *z*=lot number code)

Pin Name	Pin Number	Description
BAT	1,2,3,4,5,32	Power input/output pin, decouple this pin to PGND with at least a 10μF ceramic capacitor. This pin is the power input in source mode and the power output in sink mode.
LX1	6,30,31	Switching node 1.
BS1	7	Boot-strap pin. Supply high side gate driver. Connect a 0.1μF ceramic capacitor between the BS1 and the LX1 pin. Do not connect a resistor in series with the capacitor.
EN	8	IC enable control pin, logic high enable. This pin is internally pulled high by 400nA pull-up current.
VCC	9	3.3V LDO output, power supply for internal driver and control circuits. Decouple this pin to SGND with a minimum of 4.7μF ceramic capacitor.
FB	10	Sink mode output feedback pin. Connect this pin to the center point of the output resistor divider to adjust the V_{BAT} output voltage: $V_{BAT}=1V \times (R_{TOP}+R_{BOT})/R_{BOT}$.
COMP	11	Compensation pin. Connect the RC network between this pin and ground.
SGND	12	Signal ground.
ADDR	13	The device address set pin. Ground this pin to select 0x70. Connect this pin to GND with an external resistor to select 0x71 ($50k\Omega < R_{ADDR} < 100k\Omega$) or 0x72 ($400k\Omega < R_{ADDR} < 500k\Omega$). Float this pin to select 0x73.
SDA	14	I ² C interface serial data pin. Logic level input/output.
SCL	15	I ² C interface serial clock pin. Logic level input.
/INT	16	The /INT pin is an open-drain output. When an interrupt event happens, the /INT pin is internally pulled low to inform the host about fault condition. After the host reads the interrupt register, the /INT pin is externally pulled high. A 10kΩ pull-up resistor is recommended.
ISEN	17	Current sense pin. Connect a 10mΩ resistor R_{SENSE} between VBUS and ISEN to detect source mode output current.
BS2	18	Boot-strap pin. Supply high side gate driver. Connect a 0.1μF ceramic capacitor between the BS2 and the LX2 pin. Do not connect a resistor in series with the capacitor.

Pin Name	Pin Number	Description
LX2	19,26,27	Switching node 2.
PGND	28,29, Exposed Pad	Power ground.
VBUS	20,21,22,23, 24,25	Power input/output pin, decouple this pin to PGND with at least a 10 μ F ceramic capacitor. This pin is the power output in source mode and the power input in sink mode.

Block Diagram

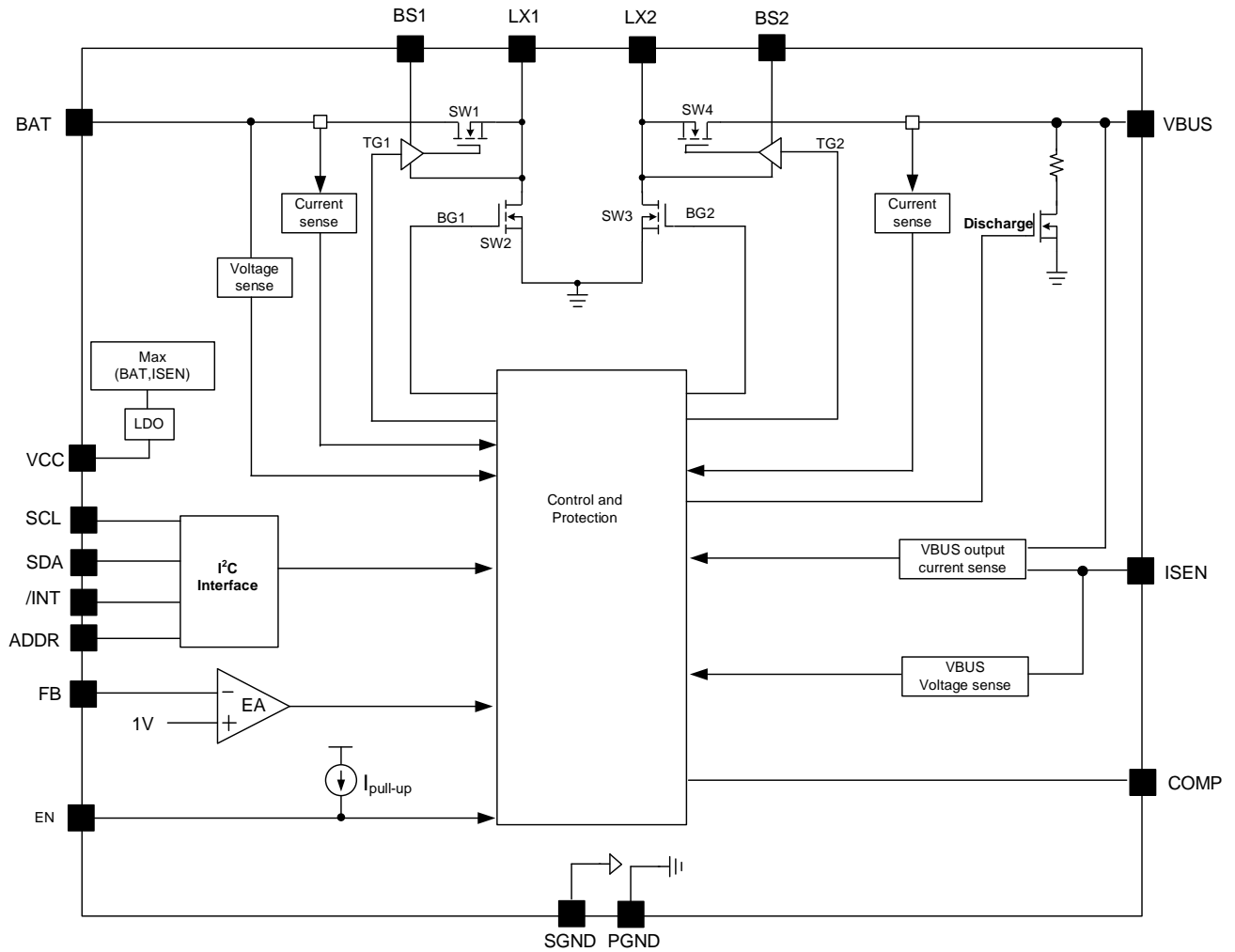

Figure.2 Block Diagram

Absolute Maximum Ratings (Note 1)

BAT, LX1, LX2, VBUS, ISEN, EN, SDA, SCL, FB, COMP	-----	-0.3V to 30V
BS-LX, VCC, ADDR, /INT	-----	-0.3V to 4V
Power Dissipation, P _D @ T _A = 25°C QFN4×4-32	-----	4W
Package Thermal Resistance (Note 2)		
θ _{JA}	-----	28°C/W
θ _{JC}	-----	2.8°C/W
Junction Temperature	-----	150°C
Lead Temperature (Soldering, 10 sec.)	-----	260°C
Storage Temperature Range	-----	-65°C to 150°C
Dynamic LX Voltage in 50ns Duration	-----	-5V to 31V

Recommended Operating Conditions (Note 3)

BAT Input Voltage	-----	4V to 28V
VBUS Voltage	-----	4V to 28V
Junction Temperature Range	-----	-40°C to 125°C
Ambient Temperature Range	-----	-40°C to 85°C

Electrical Characteristics

(V_{BAT} = 12V, V_{VBUS} = 12V, T_A = 25°C, unless otherwise specified)

Parameter	Symbol	Test Conditions	Min	Typ	Max	Unit
BAT Voltage Range	V _{BAT}		4		28	V
VBUS Voltage Range	V _{VBUS}		4		28	V
LDO Voltage	VCC	I _{LDO} = 50mA	3.12	3.3	3.37	V
LDO Current Limit	I _{LMT_LDO}			100		mA
LDO Dropout Voltage	V _{DROPOUT}	I _{LDO} = 50mA		250		mV
Quiescent Current	I _Q	No switching		310	410	μA
Shutdown Current	I _{SD}	IC is disabled		9.6	15.5	μA
Feedback Reference Voltage	V _{REF}	Sink mode	0.97	1	1.03	V
FB Input Current	I _{FB}		-50		50	nA
VBUS Voltage Set-point	V _{VBUS,SET}	Source mode, VBUS voltage setting register 0x01[5:3]='101'	11.82	12	12.18	V
VBUS OVP Threshold	V _{VBUS,OVP}	VBUS OVP point 0x02[4:3]='10'		120		% V _{VBUS,SET}
Internal Power MOSFET R _{DS(ON)}	R _{DS(ON)}			25		mΩ
Inductor Average Current Limit	I _{AVG}	0x03[7:6]='00'		6		A
		0x03[7:6]='10'		8		A
		0x03[7:6]='11'		10		A
Inductor Peak Current Limit	I _{PK}	0x03[7:6]='00'	6.8	8.8	11.1	A
		0x03[7:6]='10'	8.2	10.4	12.5	A
		0x03[7:6]='11'	10.2	13.2	15.8	A
VBUS/BAT Input UVLO Threshold	V _{UVLO}		3.3		3.7	V
UVLO Hysteresis	V _{HYS}			0.2		V
EN Logic High Threshold	V _{ENH}		1.5			V
EN Logic Low Threshold	V _{ENL}				0.5	V
VBUS Output Current Limit Voltage Threshold	V _{VBUS,ILIM}	0x02[7:5]='000'	9	18	27	mV
		0x02[7:5]='001'	14	23	32	mV
		0x02[7:5]='010'	19	28	37	mV

		0x02[7:5]='011'	24	33	41	mV
		0x02[7:5]='100'	28	37	46	mV
		0x02[7:5]='101'	38	47	55	mV
		0x02[7:5]='110'	47	56	65	mV
		0x02[7:5]='111'	62	66	71	mV
Oscillator Frequency	f _{OSC}	0x01[7:6]='01'	425	500	575	kHz
Min On Time	t _{ON_MIN}			150		ns
Thermal Shutdown Temperature	T _{SD}			150		°C
Thermal Shutdown Hysteresis	T _{HYS}			15		°C
Soft-start Time	t _{ss}	Source mode, V _{VBUS} =5V		1.5		ms
ADC Control						
ADC Resolution				8		Bits
ADC Voltage Sense Accuracy		V _{BAT} =23V	-5		5	%
ADC Current Sense Accuracy		V _{VBUS} -V _{ISEN} =71mV	-15		15	%
V _{BAT} Full Scale Range			0		25	V
V _{BUS} Full Scale Range			0		25	V
Sense Current Full Scale Range			0		71	mV
I²C COMPATIBLE INTERFACE						
Maximum Operating Frequency				400		kHz
SDA and SCL Input Logic Threshold	Logic_L				0.8	V
	Logic_H		2			V
SDA Output Low Voltage		3mA sink current			0.4	V

Note 1: Stresses beyond the “Absolute Maximum Ratings” may cause permanent damage to the device. These are stress ratings only. Functional operation of the device at these or any other conditions beyond those indicated in the operational sections of the specification is not implied. Exposure to absolute maximum rating conditions for extended periods may affect device reliability.

Note 2: θ_{JA} is measured in the natural convection at T_A = 25°C on a four-layer Silergy Evaluation Board.

Note 3: The device is not guaranteed to function outside its operating conditions.

Typical Function Description

I²C Compatible Interface

The SY9329B integrates an I²C compatible interface. To ensure compatibility with a wide range of system processors, the I²C interface supports clock speeds of up to 400kHz (“Fast-Mode”) and uses standard I²C commands. The SY9329B always operates as a slave device, and is addressed using a 7-bits slave address followed by an 8th bit, which indicates whether the transaction is a read-operation or a write-operation.

I²C Device Address

When communicating with multiple devices using the I²C interface, each device must have its own unique address so the host can distinguish among the devices. The most significant 4-bits of the device address are '1110'. The 5th, 6th and 7th-bit device address is selected by the ADDR pin.

ADDR	Device Address
ADDR short to GND	1110000
$50k\Omega < R_{ADDR} < 100k\Omega$	1110001
$400k\Omega < R_{ADDR} < 500k\Omega$	1110010
Floating or connect to VCC	1110011

START and STOP Conditions

The START condition is a HIGH to LOW transition of the SDA line while SCL is HIGH. The STOP condition is a LOW to HIGH transition on the SDA line while SCL is HIGH. A STOP condition must be sent before each START condition. The I²C master always generates the START and STOP conditions.

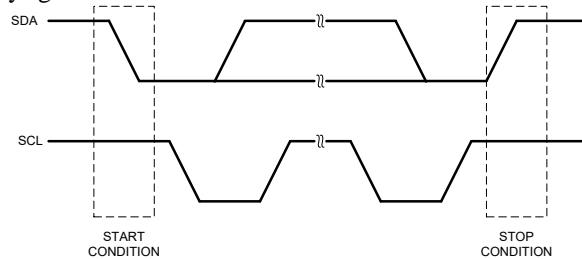

Data Validity

The data on the SDA line must be stable during the HIGH period of the SCL, unless generating a START or STOP condition. The HIGH or LOW state of the data line can only change when the clock signal on the SCL line is LOW.

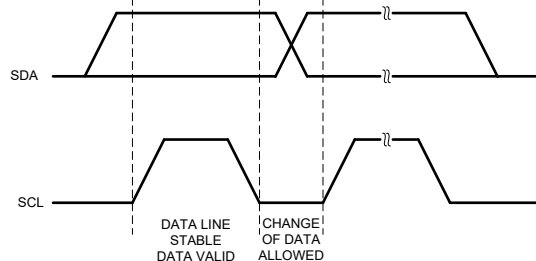

Acknowledge

Each address and data transmission uses 9-clock pulses. The ninth pulse is the acknowledge bit (ACK). After the START condition, the master sends 7-slave address bits and an R/W bit during the next 8-clock pulses. During the ninth clock pulse, the device that recognizes its own address holds the data line low to acknowledge. The acknowledge bit is also used by both the master and the slave to acknowledge receipt of register addresses and data.

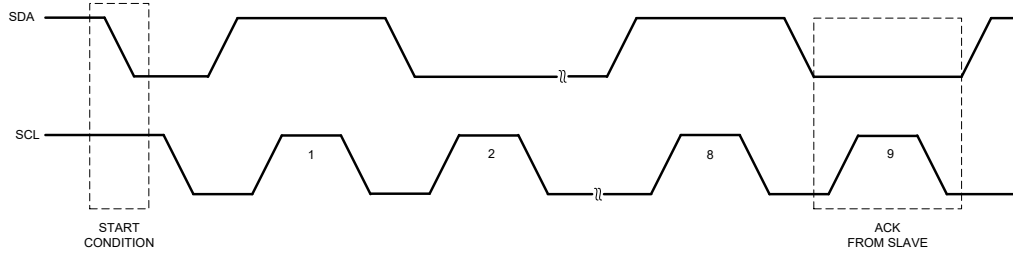

Data Transactions

All transactions start with a control byte sent from the I²C master device. The control byte begins with a START condition, followed by 7-bits of slave address followed by the R/W bit. The R/W bit is 0 for a write or 1 for a read. If any slave devices on the I²C bus recognize their address, they will acknowledge by pulling the SDA line low for the last clock cycle in the control byte. If no slaves exist at that address or are not ready to communicate, the data line will be 1, indicating a Not Acknowledge condition. Once the control byte is sent, and the slave acknowledges it, the 2nd byte sent by the master must be a register address byte. The register address byte tells the slave which register the master will write or read. Once the slave receives a register address byte, it responds with acknowledge. If a STOP condition is detected after the register address byte is received, the SY9329B takes no further action but storing the register address byte. The register address byte auto increases when multiple data bytes are transited.

Write

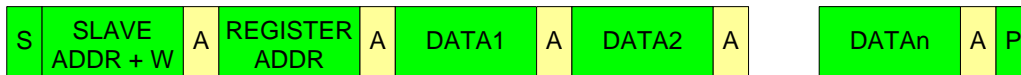

Random Read

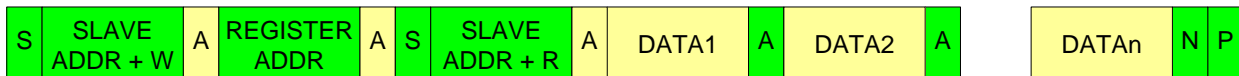

S START
 A ACKNOWLEDGE
 DRIVEN BY THE MASTER
P STOP
 N NO ACKNOWLEDGE
 DRIVEN BY SLAVE

Register Map:

Address	Data	Note
00	Control Register 1	R/W
01	Control Register 2	R/W
02	Protection setting 1	R/W
03	Protection setting 2	R/W
04	State Register	R
05	/INT Register	Read then Clear
06	BAT Voltage Value Register	R
07	VBUS Voltage Value Register	
08	VBUS Output Current Sense Voltage Register	

Control Register1 (0x00)

Name	# of Bits	Access	Default	Description
Regulator Enable	7	R/W	0	0:Disable 1:Enable
Low Battery Voltage Setting	6	R/W	0	000:10.2V[12V Car Battery] 001:10.7V[12V Car Battery] 010:11.2V [12V Car Battery] 011:11.7V [12V Car battery] 100: 22.0V [24V Car Battery] 101: 22.5V [24V Car Battery]
	5	R/W	0	110: 23V [24V Car Battery] 111:23.5V [24V Car Battery]
	4	R/W	0	
ADC ON/OFF	3	R/W	0	0:Inactive; 1:Active
ADC Mode Select	2	R/W	0	0: Single detect mode; 1: Auto detect mode
VBUS Discharge Control	1	R/W	0	0: Active discharge when regulator is disabled 1: Inactive discharge when regulator is disabled
Reserved	0	R/W	0	

Control Register2 (0x01)

Name	# of Bits	Access	Default	Description
Switching Frequency	7	R/W	1	00: 250KHz 01: 500KHz
	6	R/W	1	10: 750KHz 11: 1MHz
VBUS Voltage Setting	5	R/W	0	000:5V 001:5V 010:5V
	4	R/W	0	011:9V 100:10V 101:12V
	3	R/W	0	110:15V 111: 20V If 0x00[7]='0', this bit is reset to '0' and cannot be overwritten
VBUS Voltage Adjust	2	R/W	0	000: -2.5% 001: -1.25% 010: ±0%
	1	R/W	1	011: +1.25% 100:+2.5% 101: +3.75%
	0	R/W	0	110:+5% 111:+6.25%

Protection setting 1 (0x02)

Name	# of Bits	Access	Default	Description
VBUS Output Current Limit Voltage Threshold (Source mode)	7:5	R/W	011	000: 18mV
				001: 23mV
				010: 28mV
				011: 33mV
				100: 37mV
				101: 47mV
				110: 56mV
				111: 66mV
VBUS OVP Threshold	4	R/W	1	00:110% $V_{BUS,SET}$
	3	R/W	0	01:115% $V_{BUS,SET}$
				10:120% $V_{BUS,SET}$
11:125% $V_{BUS,SET}$				
VBUS UVP Threshold	2	R/W	1	00:50% $V_{BUS,SET}$
	1	R/W	0	01:60% $V_{BUS,SET}$
				10:70% $V_{BUS,SET}$
11:80% $V_{BUS,SET}$				
Reserved	0	R/W	0	

Protection setting 2 (0x03)

Name	# of Bits	Access	Default	Description
Inductor Average Current Limit Setting	7	R/W	0	00: 6A
	6	R/W	0	01: 6A
				10: 8A
11: 10A				
Inductor Average Current Limit Protection Mode	5	R/W	0	0: Latch off: 0x00[7] is reset to '0' 1: Auto recover: 0x01[5:3] is reset to '000'
VBUS Under Voltage Protection Mode	4	R/W	0	0: Latch off: 0x00[7] is reset to '0' 1: Auto recover: hiccup mode, 0x01[5:3] is reset to '000'
Over Temperature Protection Mode	3	R/W	0	0: Latch off: 0x00[7] is reset to '0' 1: Auto recover, 0x01[5:3] is reset to '000'
Bidirectional Mode	2	R/W	0	0: Source mode 1: Sink mode If 0x00[7]='0', this bit is reset to '0' and cannot be overwritten
Reserved	1	R/W	0	
Reserved	0	R/W	0	

State Register (0x04)

Name	# of Bits	Access	Description
Power Good State	7	R	0: Power is not in good range 1: Power good (feedback is 90%~120% Vref)
BAT/VBUS Voltage Relation	6	R	0:BAT voltage > VBUS voltage 1: BAT voltage < VBUS voltage
BAT Power State	5	R	0: Normal 1: Low BAT voltage
Reserved	4:0	R	

Interrupt Register (0x05)

Name	# of Bits	Access	Description
ADC Data Ready	7	Read then Clear	0: None 1: Data ready
VBUS Over Current Limit	6	Read then Clear	0: Normal 1:VBUS output current OCP
Inductor Current Protection	5	Read then Clear	0: Normal 1: Inductor OCP
VBUS UVP	4	Read then Clear	0: Normal 1:UVP
Over Temperature Protection	3	Read then Clear	0: Normal 1: OTP
Reserved	2:0	Read then Clear	

BAT Voltage Register (0x06)

Name	# of Bits	Access	Description
BAT Voltage Value	7:0	R	00000000: 0V 00000001: 0.098V 11111111: 25V

VBUS Voltage Register (0x07)

Name	# of Bits	Access	Description
VBUS Voltage Value	7:0	R	00000000: 0V 00000001: 0.098V 11111111: 25V



VBUS Output Current Sense Voltage Register (0x08)

Name	# of Bits	Access	Description
VBUS Output Current Sense Voltage	7:0	R	00000000: 0mV 00000001: 0.278mV 11111111: 71mV

Typical Performance Characteristics

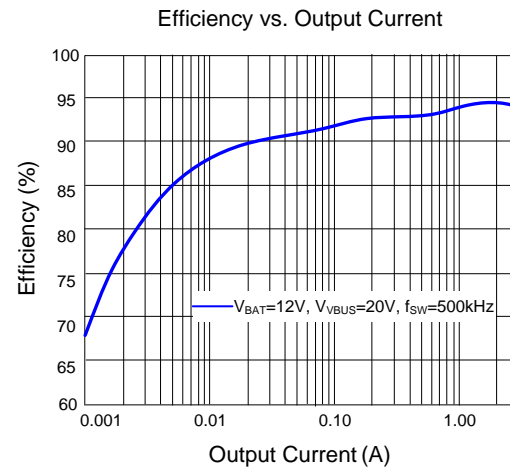
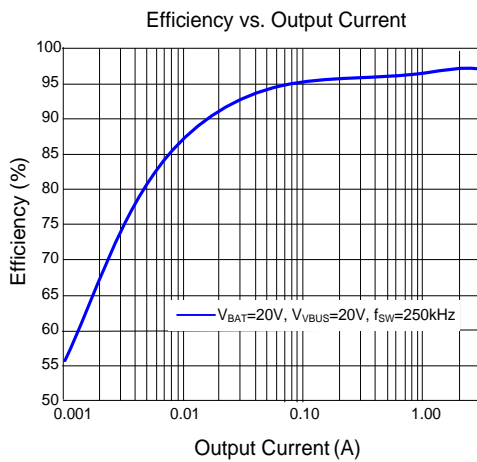
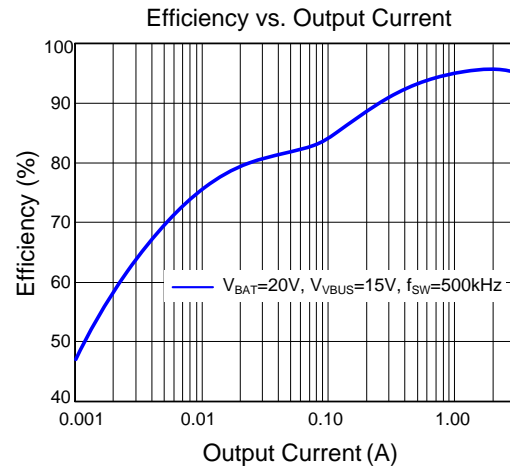
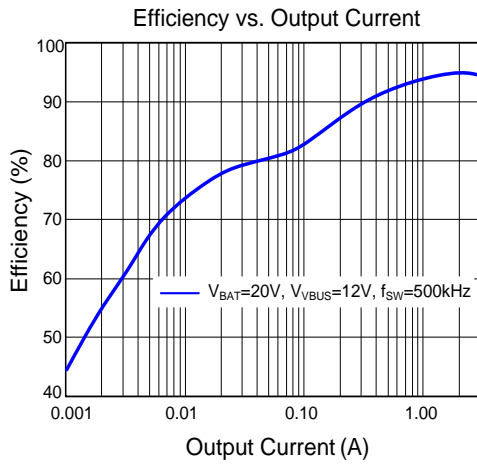
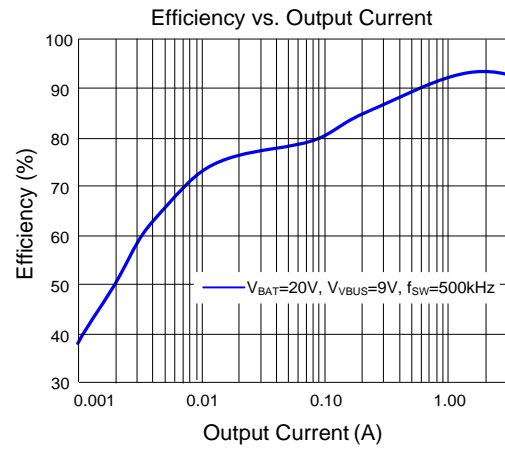
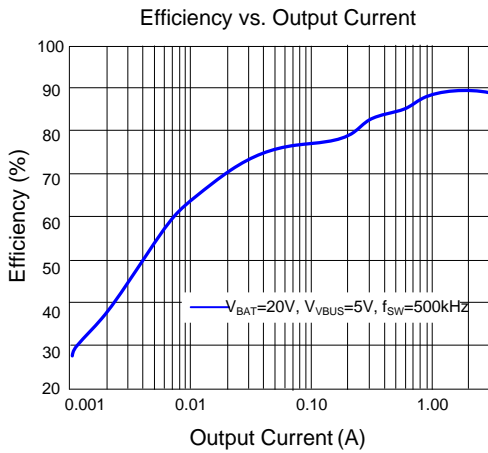

Short Circuit Test (Auto Recover)
 ($V_{BAT}=20V, V_{VBUS}=20V, R_{LOAD}=6.7\Omega$)

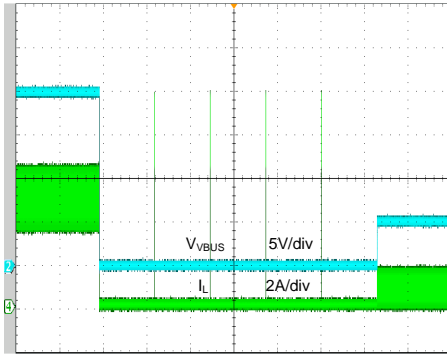

Time (2s/div)

Regulator Enable
 ($V_{BAT}=20V, V_{VBUS}=5V, I_{LOAD}=3A$)

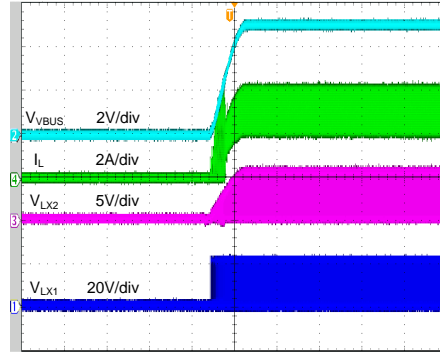

Time (2ms/div)

Regulator Disable
 ($V_{BAT}=20V, V_{VBUS}=5V, I_{LOAD}=3A$)

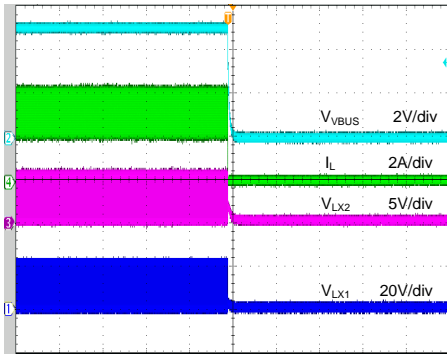

Time (2ms/div)

Output Ripple
 ($V_{BAT}=12V, V_{VBUS}=15V, I_{LOAD}=2A$)

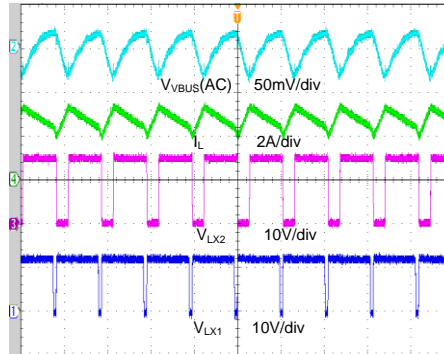

Time (2µs/div)

Output Ripple
 ($V_{BAT}=20V, V_{VBUS}=12V, I_{LOAD}=3A$)

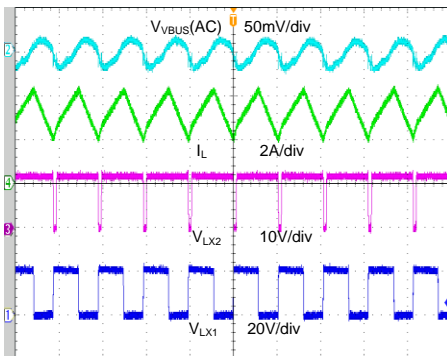

Time (2µs/div)

Output Ripple
 ($V_{BAT}=20V, V_{VBUS}=20V, I_{LOAD}=3A$)

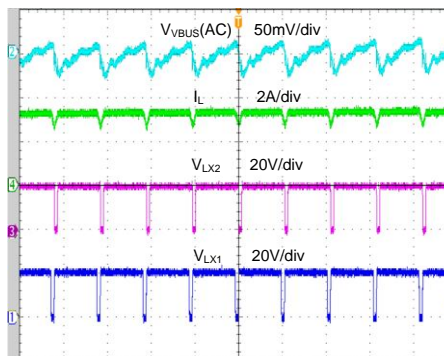

Time (2µs/div)

Application Information

Bidirectional Buck-Boost Regulator Operation

Mode

The SY9329B is a bidirectional device which can be operated under both source mode and sink mode. 0x03[2]='0' selects source mode while 0x03[2]='1' selects sink mode.

Under source mode, which is also the default mode, the BAT pin is connected to the power input and the VBUS pin is the power output. The output voltage V_{VBUS} is configured by 'VBUS Voltage Setting' register 0x01[5:3]. Once the 'Regulator Enable' bit is cleared (0x00[7]='0'), operation mode will be reset to source mode (0x03[2] is reset to '0' and cannot be overwritten).

Under sink mode, the VBUS pin is connected to the power input, the BAT pin is the power output and the FB pin is the feedback input. The output voltage V_{BAT} is programmed by external voltage divider (see Figure3) with the 1V internal voltage reference as given in equation (1).

$$V_{BAT} = 1V \times \frac{R_{TOP} + R_{BOT}}{R_{BOT}} \quad (1)$$

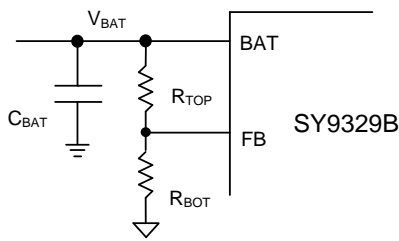

Figure3. Schematic of V_{BAT} under Sink Mode

Interrupt

When an interrupt event happens, the open-drain /INT pin is pulled low to inform the host. After the host reads the interrupt register, the /INT pin will be pulled high by an external pull-up resistor.

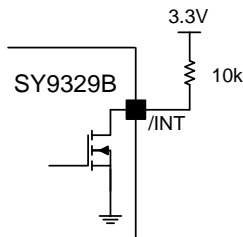

Figure4. Description of Interrupt Function

Under Voltage Protection

The SY9329B activates UVP (under voltage protection) function when output short occurs. There are two UVP protection modes. One is latch off operation by setting 0x03[4]='0', the other is auto recover operation with 0x03[4]='1'.

Latch off Operation: Once the output voltage is lower than UVP threshold for 1ms, the regulator will be disabled (0x00[7]='0').

Auto Recover Operation (Hiccup Mode): When output voltage is lower than UVP threshold for 1ms, the device will shut down for approximately 2.6s. The device will then restart with a complete soft-start cycle. If the short circuit condition remains another 'hiccup' cycle of shutdown and restart will continue indefinitely unless the OTP threshold is reached.

In applications where the wire length from the output of the SY9329B to the load is relative long, the parasitic inductance of the wire, L_{WIRE} , can't be neglected. If short circuit event happens on the load side, the energy stored in the L_{WIRE} will reversely charge the output capacitor, and cause high negative voltage on C_{OUT} . This may cause potential risk to the safe operating of the IC when negative voltage exceeds -0.7V. To avoid this happening, a Schottky diode in parallel with C_{OUT} can be used as shown below. Same solution can be employed when the IC works under sink mode, and the BAT will be shorted.

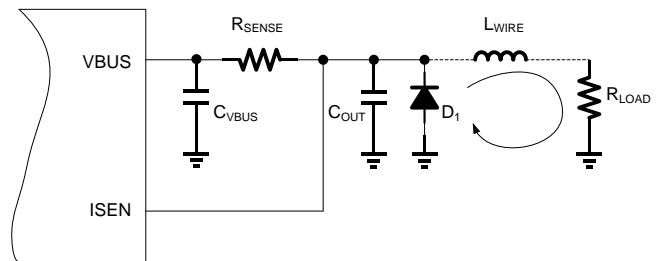

Average Inductor Current Limit

When average inductor current is greater than the threshold, the internal control loop will regulate the average inductor current by decreasing duty cycle. Both latch off operation and auto recover operation are provided by the device: 0x03[5]='0' enters latch off operation, and 0x03[5]='1' enters auto recover operation.

Latch off Operation: When average inductor current exceeds a certain threshold for 1ms, the regulator will be disabled (0x00[7]='0').

Auto Recover Operation: The device will regulate the average inductor current to the setting value. The IC resumes normal operation when the fault condition is removed.

VBUS Output Current Limit

The SY9329B provides a function for VBUS output current limit by sensing the voltage drop between VBUS pin and ISEN pin (as shown in figure5). Once the voltage difference ($V_{VBUS}-V_{ISEN}$) exceeds the voltage threshold, which can be configured by register 0x02[7:5], the internal control loop will regulate the output current by decreasing duty cycle until UVP or OTP is triggered. Noticing that the effects of R_{PIN} and R_{WIRE} cannot be ignored, the actual limit current I_{LIMIT} can be calculated as given in Equation (2):

$$I_{LIMIT} = \frac{V_{VBUS} - V_{ISEN}}{R_{SENSE} + R_{PIN} + R_{WIRE}} \quad (2)$$

where $R_{PIN} \approx 1.65m\Omega$.

R_{WIRE} depends on PCB layout.

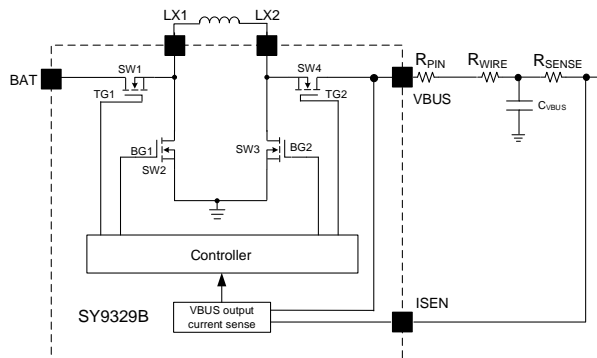

Figure5. Description of VBUS Output Current Limit

Note: The VBUS output current limit only functions under source mode, after finishing soft-start.

Over Temperature Protection

The device provides two protection modes for OTP (over temperature protection). If 0x03[5]=0', it selects latch off operation, and if 0x03[3]=1', it is auto recover operation

Latch off Operation: The regulator will be disabled when the junction temperature exceeds 150°C.

Auto Recover Operation: The regulator stops switching when the junction temperature exceeds 150°C. Once the junction temperature falls below 135°C, the device will resume operation.

Device Enable

When the device is enabled, LDO is turned on, and then I²C interface is fully functional. The device can be enabled when BAT voltage is above 3.5V and EN voltage is greater than 1.2V, or VBUS voltage exceeds 3.5V (see Figure6). To disable the device, the regulator should be disabled through I²C first, and then the device will automatically discharge VBUS. After VBUS falls below 3.5 V, pulled EN low to totally disable the device.

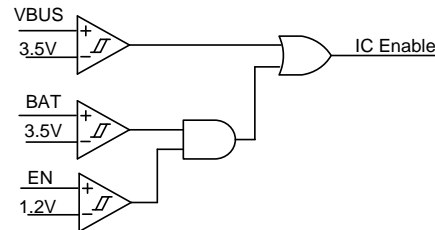
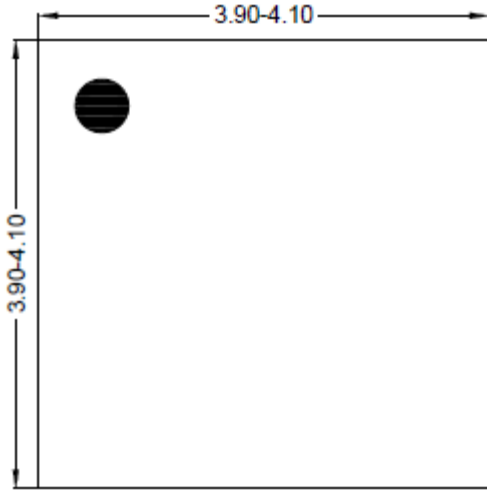
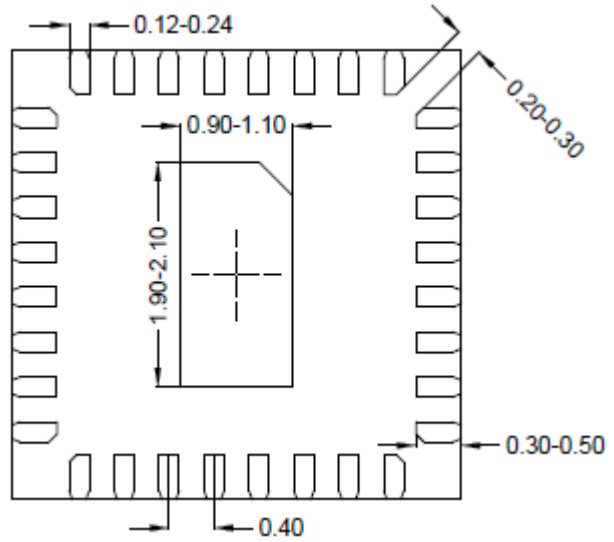

Figure6. Description of the IC Enable Function

QFN4x4-32 Package Outline Drawing



Top View



Bottom View

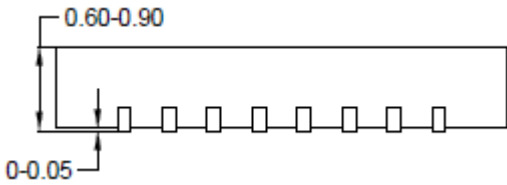

Side View

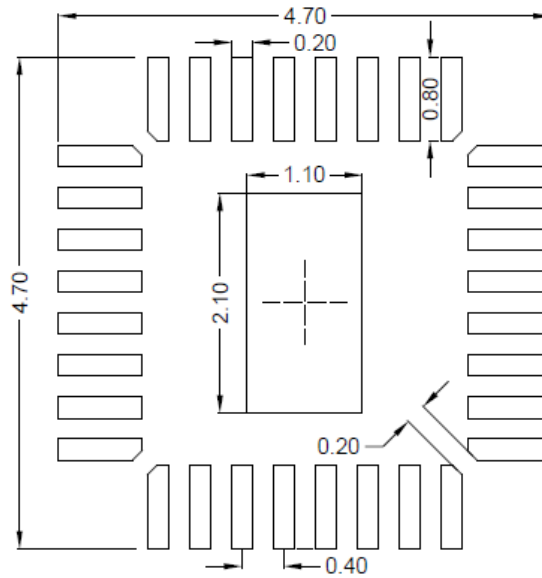

**Recommended PCB layout
(Reference only)**

Notes: All dimension in millimeter and exclude mold flash & metal burr.

Taping & Reel Specification

1. Taping orientation

QFN4x4

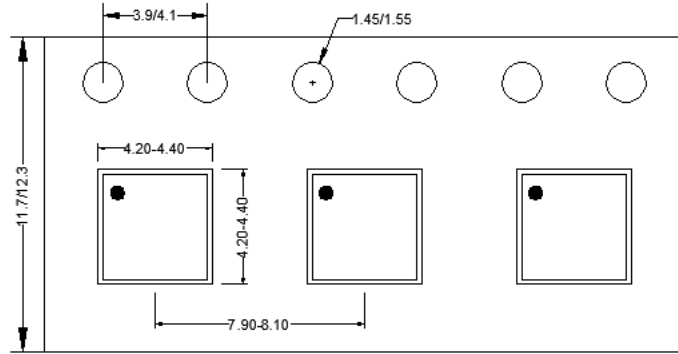

Feeding direction →

2. Carrier Tape & Reel specification for packages

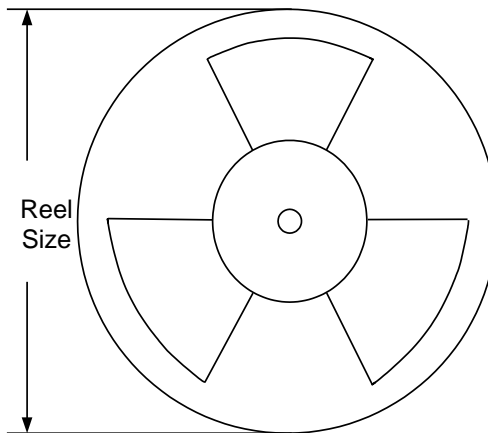

Package type	Tape width (mm)	Pocket pitch(mm)	Reel size (Inch)	Trailer * length(mm)	Leader * length (mm)	Qty per reel (pcs)
QFN4x4	12	8	13"	400	400	5000

Revision History

The revision history provided is for informational purpose only and is believed to be accurate, however, not warranted. Please make sure that you have the latest revision.

Date	Revision	Change
June 13, 2025	Revision 1.0A	Add the following description to the BS1 pin description and the BS2 pin description (Page2): ---- Do not connect a resistor in series with the capacitor.
Mar.15, 2022	Revision 1.0	Initial Production Release
Mar.15, 2021	Revision 0.9A	Add UL certification in Features (page1)
Apr.09, 2020	Revision 0.9	Initial Risk Production Release

IMPORTANT NOTICE

- 1. Right to make changes.** Silergy and its subsidiaries (hereafter Silergy) reserve the right to change any information published in this document, including but not limited to circuitry, specification and/or product design, manufacturing or descriptions, at any time and without notice. This document supersedes and replaces all information supplied prior to the publication hereof. Buyers should obtain the latest relevant information before placing orders and should verify that such information is current and complete. All semiconductor products are sold subject to Silergy's standard terms and conditions of sale.
- 2. Applications.** Application examples that are described herein for any of these products are for illustrative purposes only. Silergy makes no representation or warranty that such applications will be suitable for the specified use without further testing or modification. Buyers are responsible for the design and operation of their applications and products using Silergy products. Silergy or its subsidiaries assume no liability for any application assistance or designs of customer products. It is customer's sole responsibility to determine whether the Silergy product is suitable and fit for the customer's applications and products planned. To minimize the risks associated with customer's products and applications, customer should provide adequate design and operating safeguards. Customer represents and agrees that it has all the necessary expertise to create and implement safeguards which anticipate dangerous consequences of failures, monitor failures and their consequences, lessen the likelihood of failures that might cause harm and take appropriate remedial actions. Silergy assumes no liability related to any default, damage, costs or problem in the customer's applications or products, or the application or use by customer's third-party buyers. Customer will fully indemnify Silergy, its subsidiaries, and their representatives against any damages arising out of the use of any Silergy components in safety-critical applications. It is also buyers' sole responsibility to warrant and guarantee that any intellectual property rights of a third party are not infringed upon when integrating Silergy products into any application. Silergy assumes no responsibility for any said applications or for any use of any circuitry other than circuitry entirely embodied in a Silergy product.
- 3. Limited warranty and liability.** Information furnished by Silergy in this document is believed to be accurate and reliable. However, Silergy makes no representation or warranty, expressed or implied, as to the accuracy or completeness of such information and shall have no liability for the consequences of use of such information. In no event shall Silergy be liable for any indirect, incidental, punitive, special or consequential damages, including but not limited to lost profits, lost savings, business interruption, costs related to the removal or replacement of any products or rework charges, whether or not such damages are based on tort or negligence, warranty, breach of contract or any other legal theory. Notwithstanding any damages that customer might incur for any reason whatsoever, Silergy' aggregate and cumulative liability towards customer for the products described herein shall be limited in accordance with the Standard Terms and Conditions of Sale of Silergy.
- 4. Suitability for use.** Customer acknowledges and agrees that it is solely responsible for compliance with all legal, regulatory and safety-related requirements concerning its products, and any use of Silergy components in its applications, notwithstanding any applications-related information or support that may be provided by Silergy. Silergy products are not designed, authorized or warranted to be suitable for use in life support, life-critical or safety-critical systems or equipment, nor in applications where failure or malfunction of a Silergy product can reasonably be expected to result in personal injury, death or severe property or environmental damage. Silergy assumes no liability for inclusion and/or use of Silergy products in such equipment or applications and therefore such inclusion and/or use is at the customer's own risk.
- 5. Terms and conditions of commercial sale.** Silergy products are sold subject to the standard terms and conditions of commercial sale, as published at <http://www.silergy.com/stdterms>, unless otherwise agreed in a valid written individual agreement specifically agreed to in writing by an authorized officer of Silergy. In case an individual agreement is concluded only the terms and conditions of the respective agreement shall apply. Silergy hereby expressly objects to and denies the application of any customer's general terms and conditions with regard to the purchase of Silergy products by the customer.
- 6. No offer to sell or license.** Nothing in this document may be interpreted or construed as an offer to sell products that is open for acceptance or the grant, conveyance or implication of any license under any copyrights, patents or other industrial or intellectual property rights. Silergy makes no representation or warranty that any license, either express or implied, is granted under any patent right, copyright, mask work right, or other intellectual property right. Information published by Silergy regarding third-party products or services does not constitute a license to use such products or services or a warranty or endorsement thereof. Use of such information may require a license from a third party under the patents or other intellectual property of the third party, or a license from Silergy under the patents or other intellectual property of Silergy.

For more information, please visit: www.silergy.com

© 2025 Silergy Corp.

All Rights Reserved.